

Il paesaggio della trasformazione: la tarda antichità e le campagne

1) La villa tardoantica

2) Militarizzazione

3) Trasformazioni produttive

4) Abbandoni

5) insediamento e luogo di memoria

6) insediamento e luogo di culto

7) luogo di culto

8) mutamenti complessi

Il paesaggio cambia

```
graph LR; A[Il paesaggio cambia] --- B[1) La villa tardoantica]; A --- C[2) Militarizzazione]; A --- D[3) Trasformazioni produttive]; A --- E[4) Abbandoni]; A --- F[5) insediamento e luogo di memoria]; A --- G[6) insediamento e luogo di culto]; A --- H[7) luogo di culto]; A --- I[8) mutamenti complessi];
```

This reconstruction drawing (below) of a villa complex shows the magnificent main residence and the simpler farm buildings beyond its garden walls. The owner may also have had a house in a neighboring town. This bedroom (right) at Boscoreale shows the fine furniture and rich wall paintings that decorated such buildings. (Metropolitan Museum of Art)

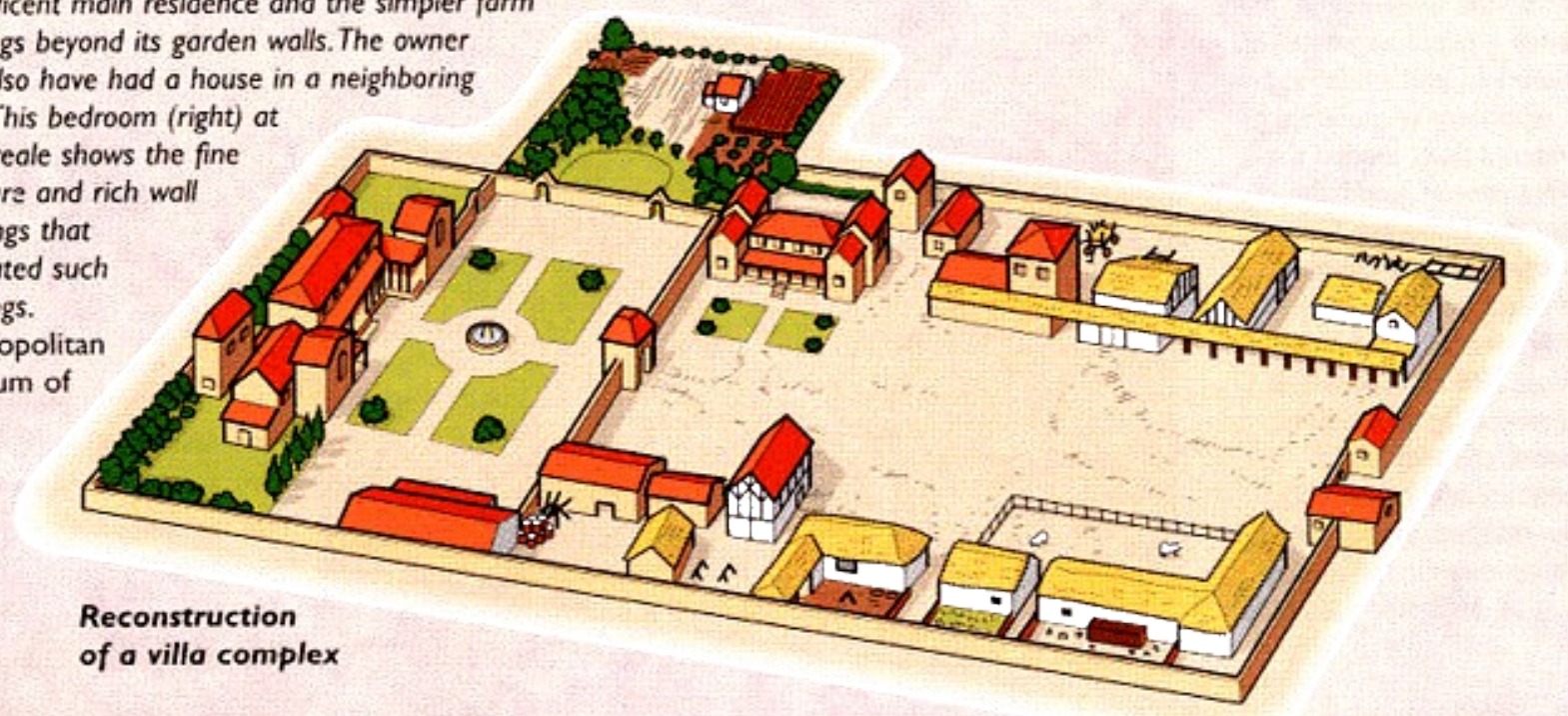

Reconstruction of a villa complex



## La questione demografica

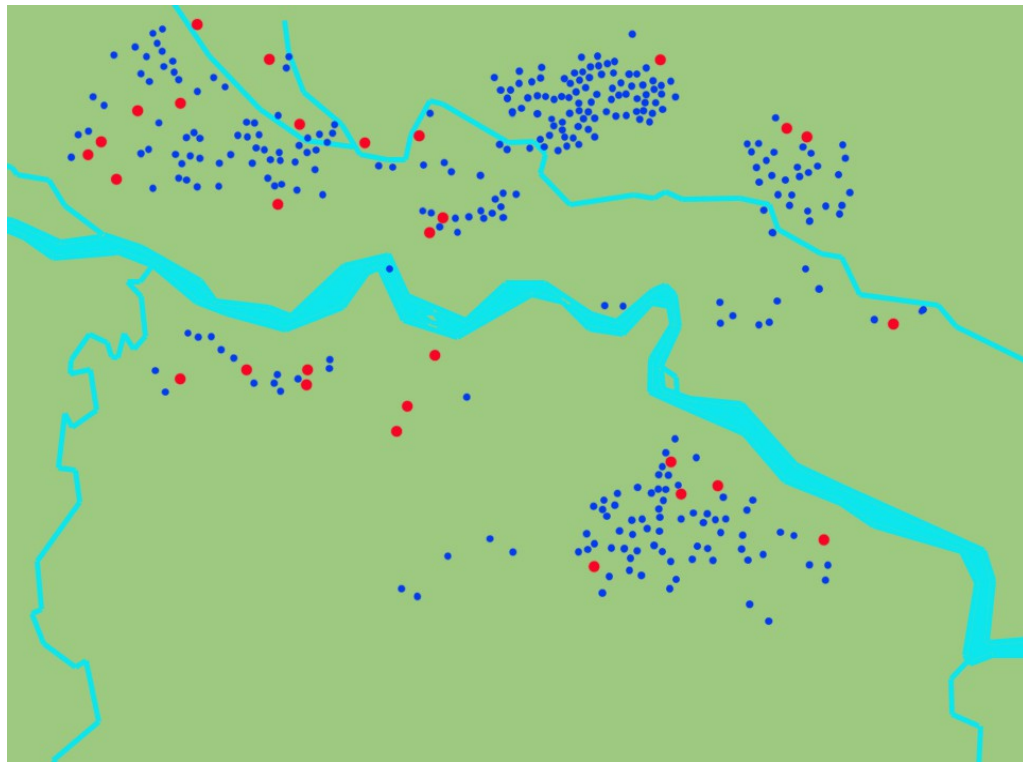

Organizzazione del popolamento  
Numero delle presenze

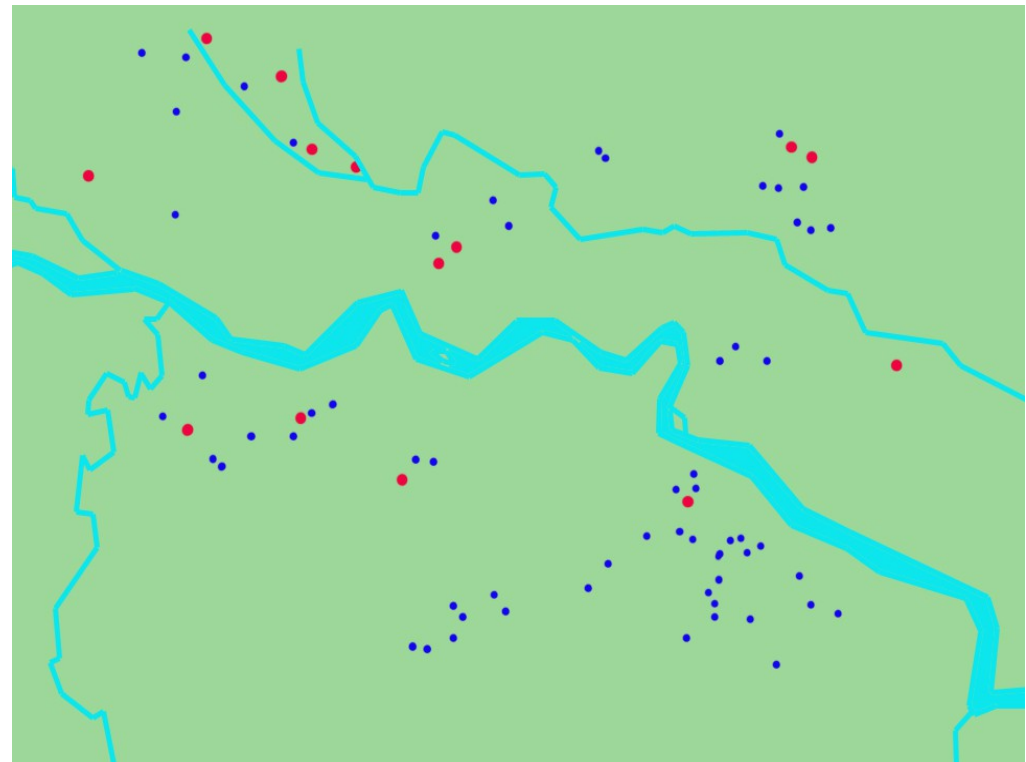

Tipologia degli insediamenti  
Distribuzione delle continuità

“Di nuovo e per la seconda volta la beatissima (Melania) ebbe a soffrire queste tentazioni del diavolo che le instillava dubbi. Essa possedeva infatti una tenuta straordinariamente lussuosa dotata di un impianto termale e di una piscina situati fra il mare da un lato e dall’altro pianure boschive popolate da vari animali in cui si svolgevano cacce. Pertanto, mentre si bagnava nella piscina poteva vedere sia le navi di passaggio sia la caccia nel bosco. Il diavolo dunque suscitava in lei tentazioni diverse mostrandole i marmi preziosi e le ricche decorazioni nonché i molti proventi e il reddito complessivo di questa proprietà. Infatti la tenuta comprendeva sessanta villulae dotate di quattrocento contadini schiavi” *Habebat enim ipsa possessio sexaginta villulas circa se habentes quadringentos servos agricultores.* (L. 18) – VERA 1986

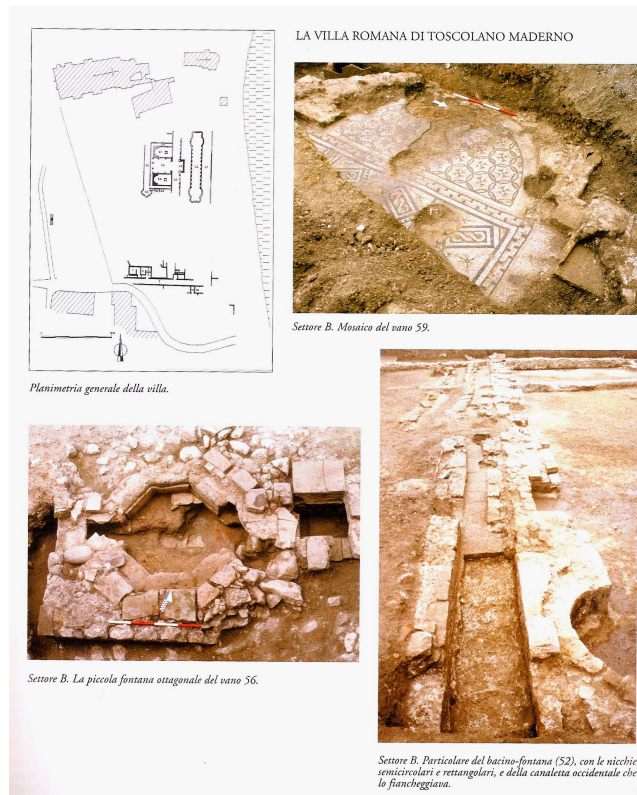
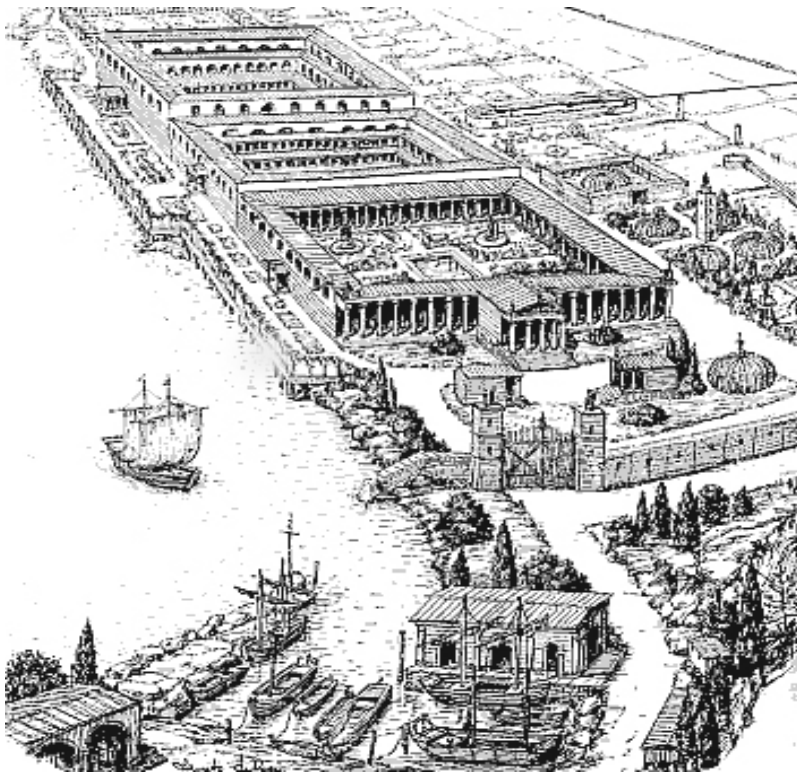

# La villa e il proprietario

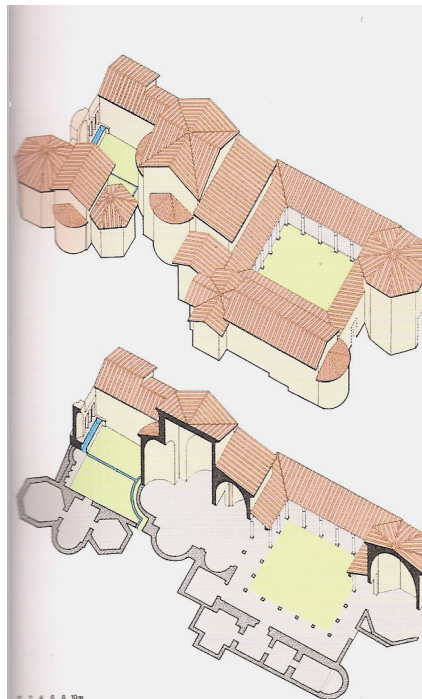
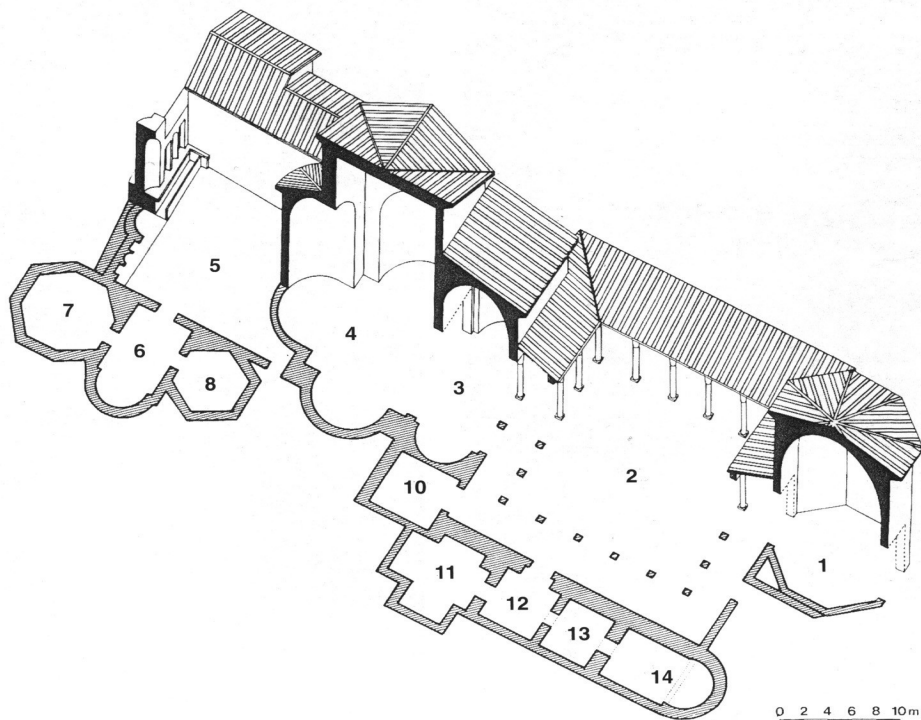
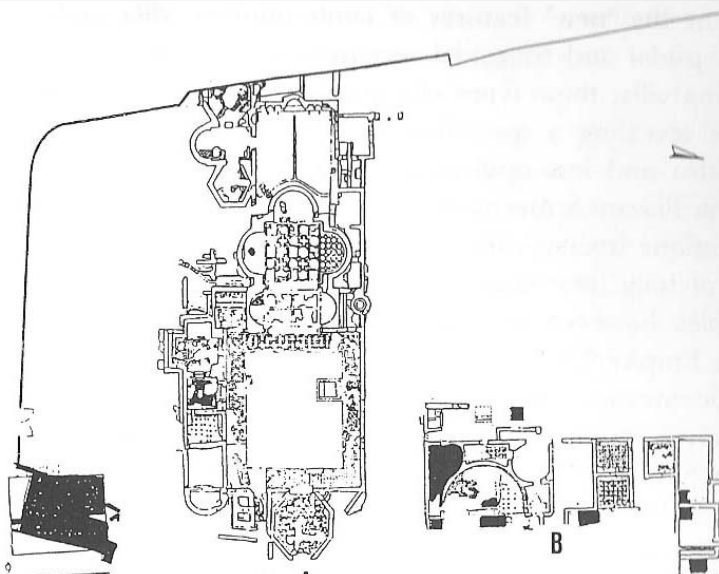

*Ipotesi restitutiva del settore A.*

## LA VILLA ROMANA DI DESENZANO



*Settore C. Vano 49-51 con ipocausto.*



*Settore A. Vano 4 (trichora), mosaico dell'abside nord.*

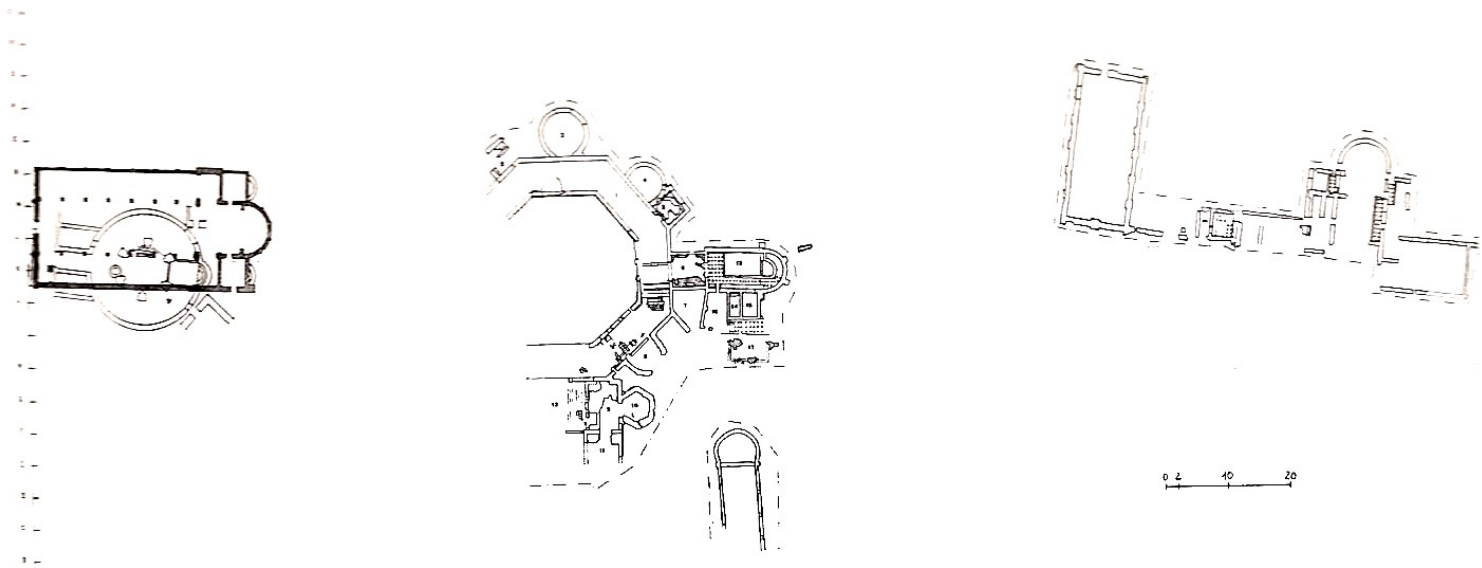

Fig. 7 Palazzo Pignano: plan of the site (after Massari, Roffia (1985) pl. 1).

## Sidonio Apollinare: l'idea di un mondo che si trasforma

Epist. VIII,8, 2

Sidonio afferma che oramai (478) solo la cultura può distinguere gli uomini migliori dagli altri, dal momento che il *gradus dignitatum* è venuto meno.

*Nam iam remotis gradibus dignitatum per quas solebant ultimo a quoque summus quisque discerni, solum erit posta nobilitatis indicium litteras nosse.*



Avitacum  
Appartiene alla  
moglie, caro il  
suocero

Epist. II, 9, 1- 10 (a Domizio)  
Contrapposizione tra città e campagna  
Vita nella villa.



Entrata nella villa



La villa è poco distante dal lago

Bagni e preparazione

La valle è un vestibolo

Assenza di descrizione economica

Pranzo con gli ospiti

Bagni in area occidentale

sed etsi nullo peregrinarum cautium rigore  
ditamur, habent tamen **tuguria** seu **mapalia** mea  
civicum frigus

Riposo

Baracche/rifugio

Capanne  
trasportabili

Visita al lago

## Il paesaggio si “militarizza”?



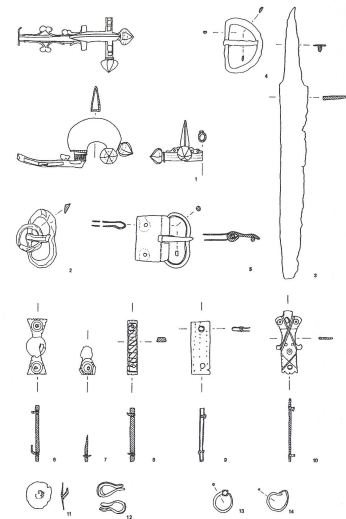
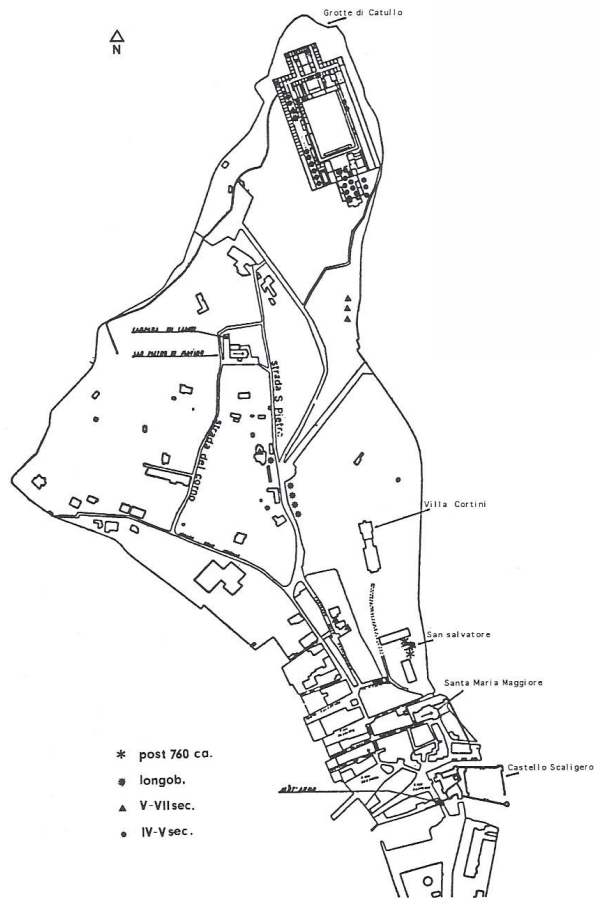

- Origine nella Tarda Antichità;
- Spazio della “vecchia villa” occupato dalla fortificazione;
- cinta settentrionale perderà ruolo nel corso del VIII secolo;
- Cinta meridionale strutturata sopra la villa romana di Vie Antiche Mura (post VI).

IX.  
Insignia viri illustris magistri officiorum.

Italiae:  
Concordensis sagittaria.  
Veronensis scutaria et armorum.  
Manutuana loritaria.  
Cremonensis scutaria.  
Ticenensis arcuaria.  
Lucensis spatharia.



Sirmione via Antiche Mura



Strutture in legno nel VII secolo

# Trasformazioni produttive

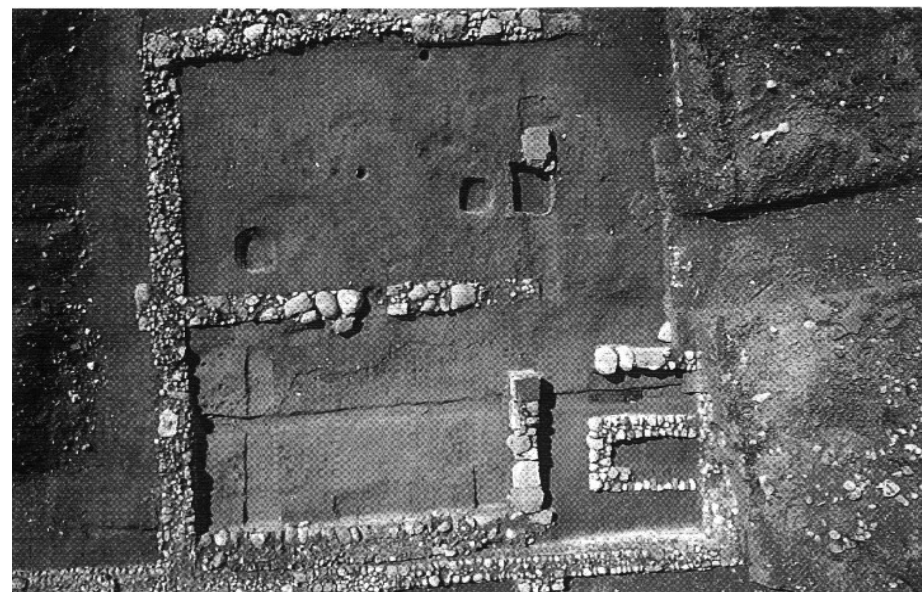
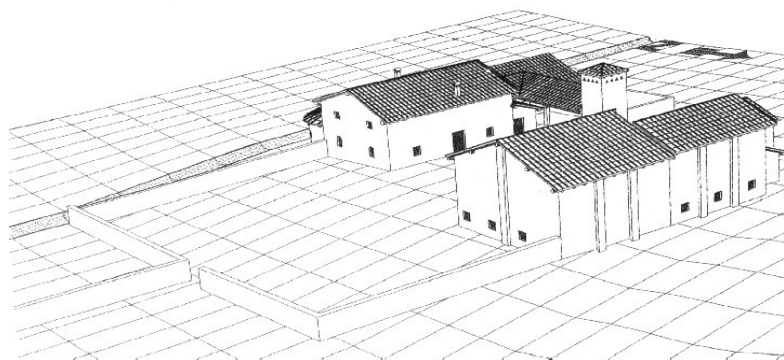
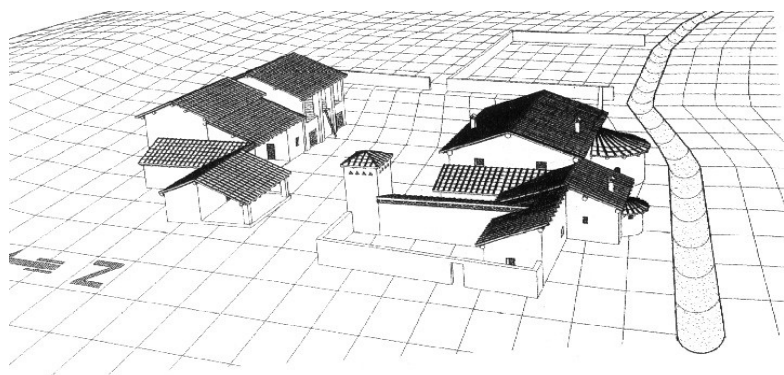

# Area Gardesana: S. Faustino di Desenzano

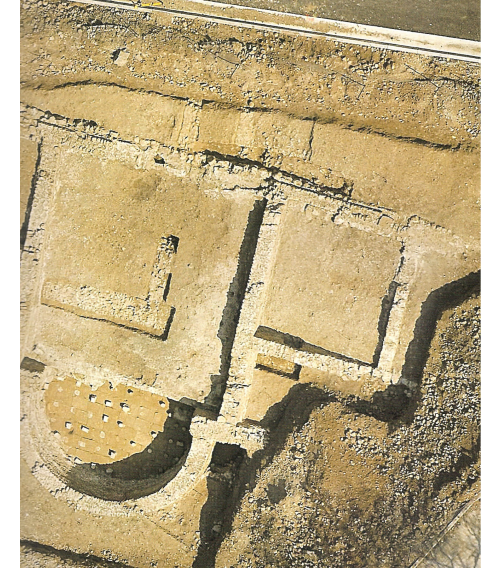

IV secolo d. C.



Metà VI-VII secolo d. C.

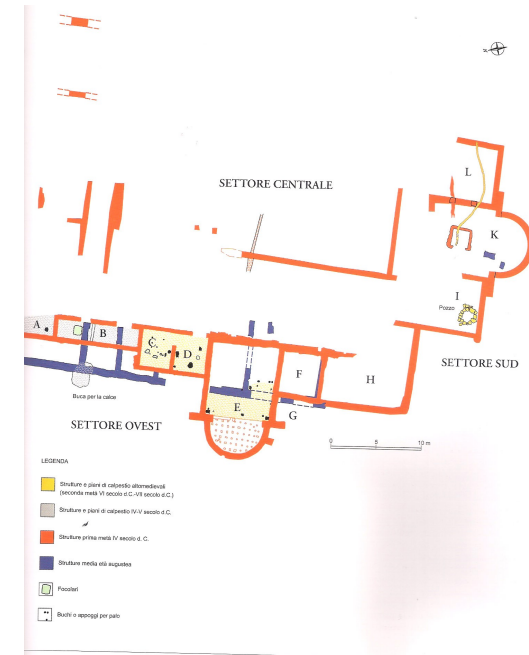

# Cavaion La Prà

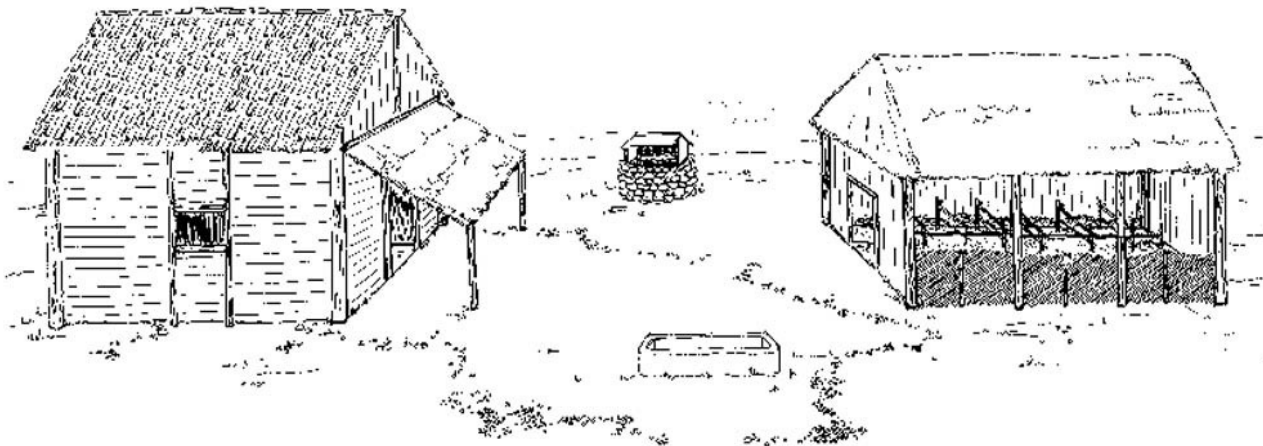



# Abbandoni

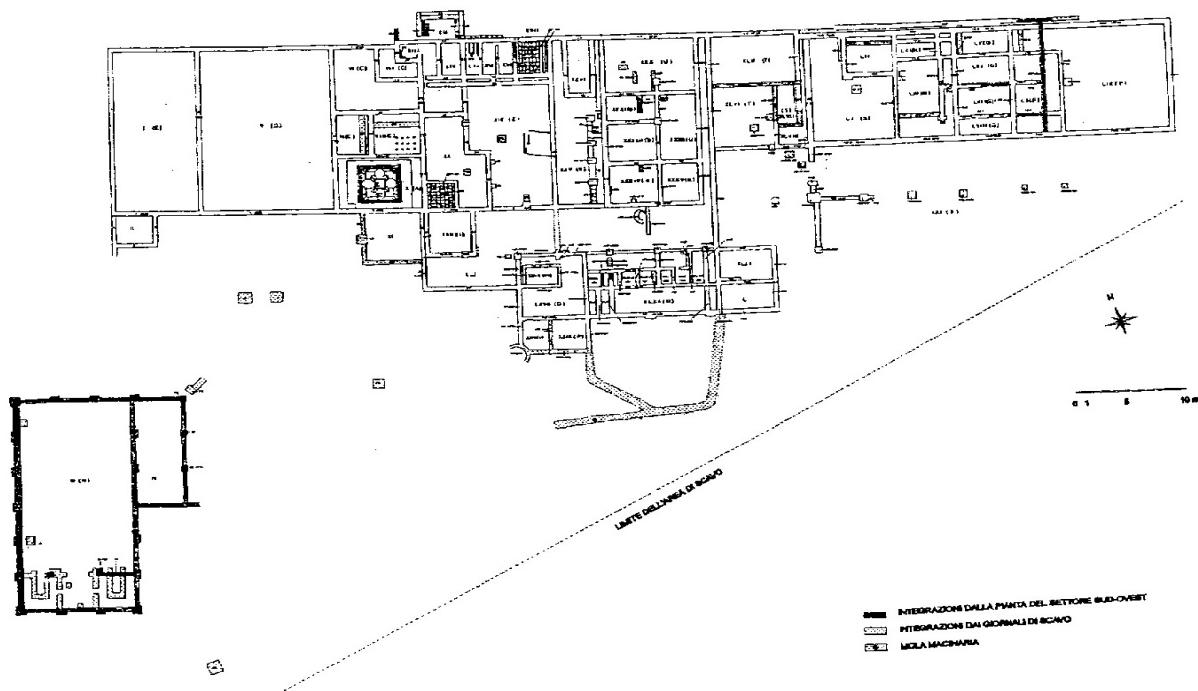

Progressivi abbandoni  
Strutture produttive  
Aree di bassa pianura

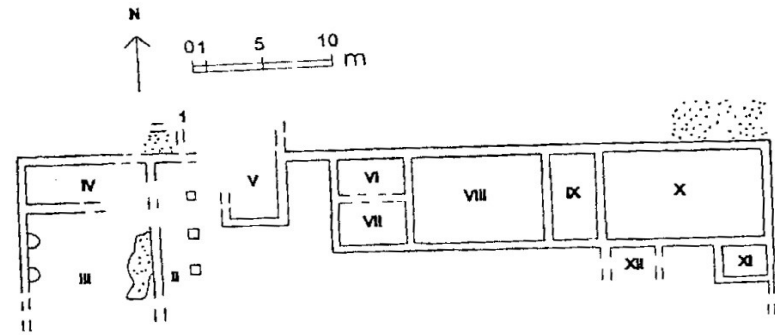

Zevio

Boschi S. Anna

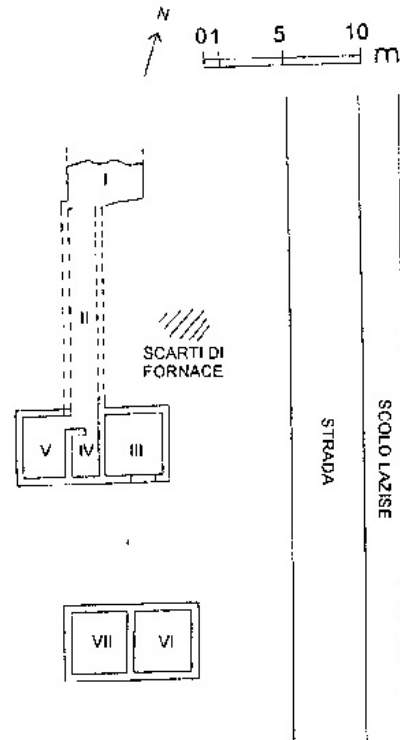
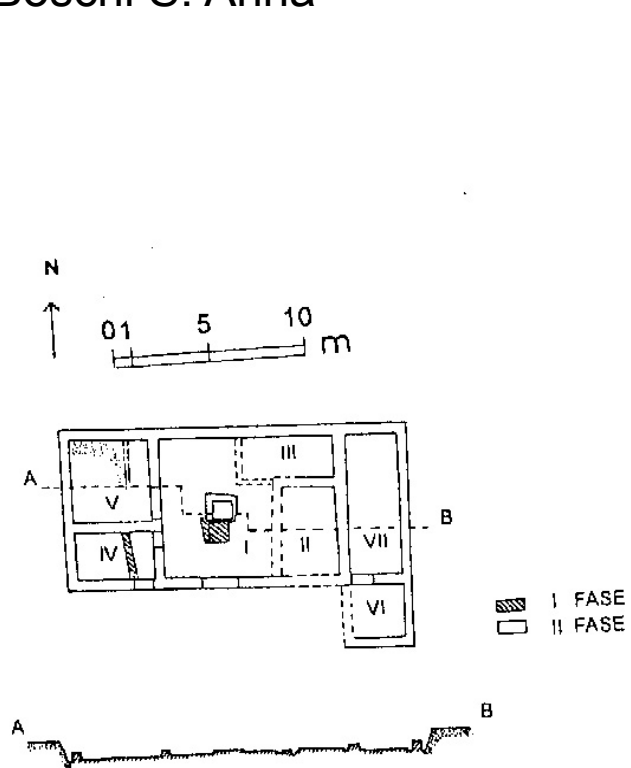

Villabartolomea

## Insediamiento e luogo di memoria

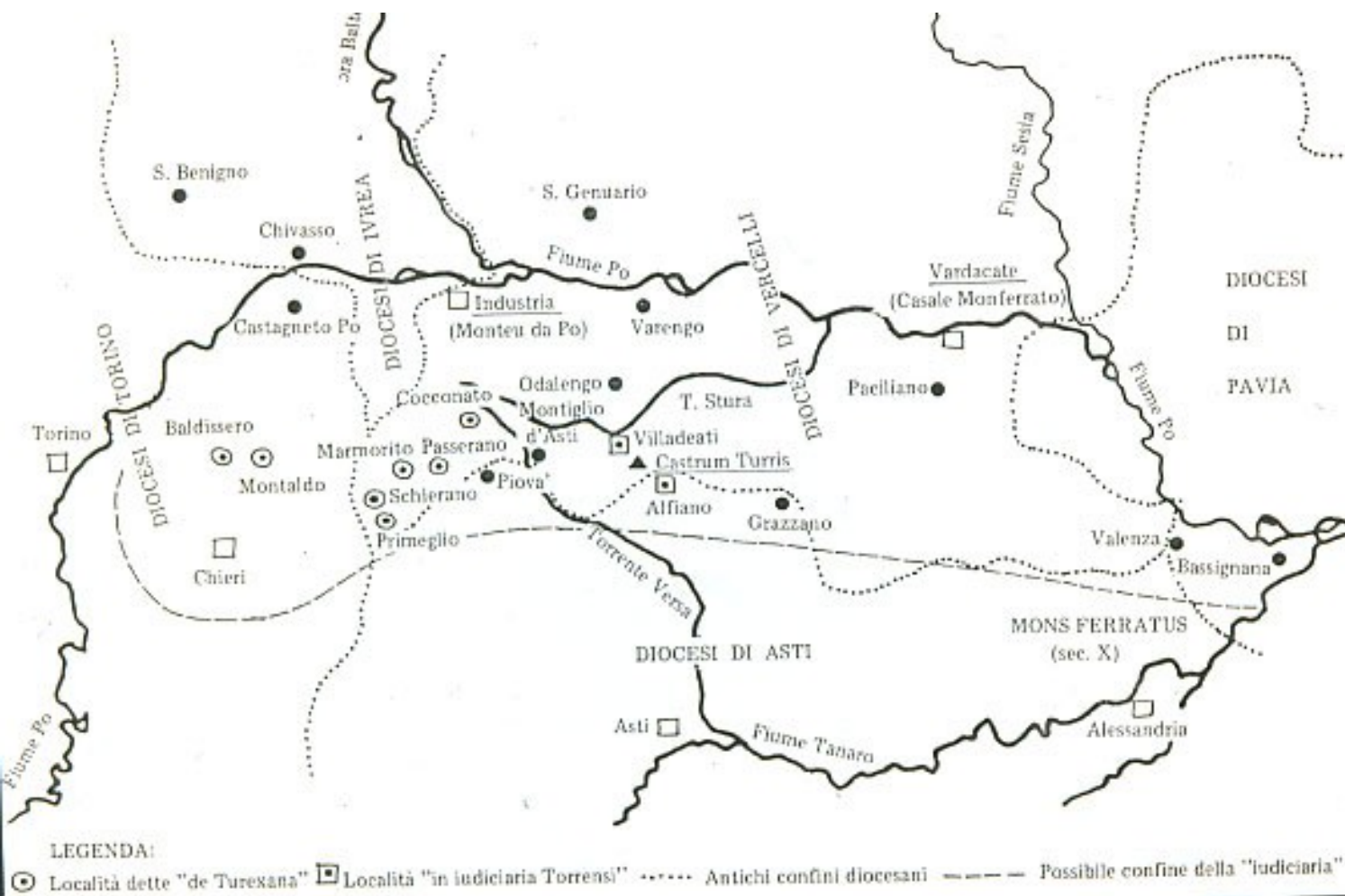

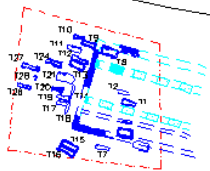

CHIESA E AREA CIMITERIALE

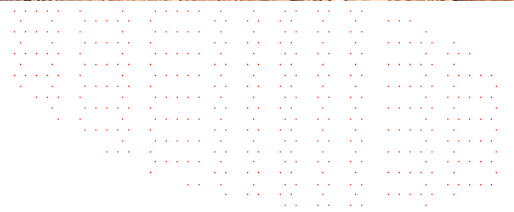

AREE DI AFFIORAMENTO SUPERFICIALE

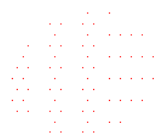

- = strutture di età romana
- = strutture di V-VI sec
- = strutture di età longobarda

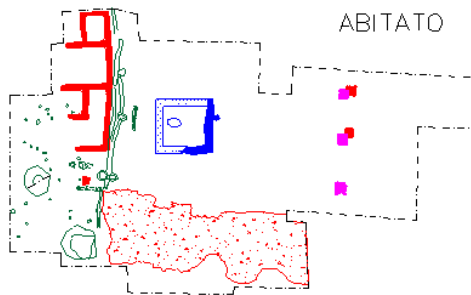

0 10 mt

## Castelletto di Brenzone: insediamento ed edificio religioso

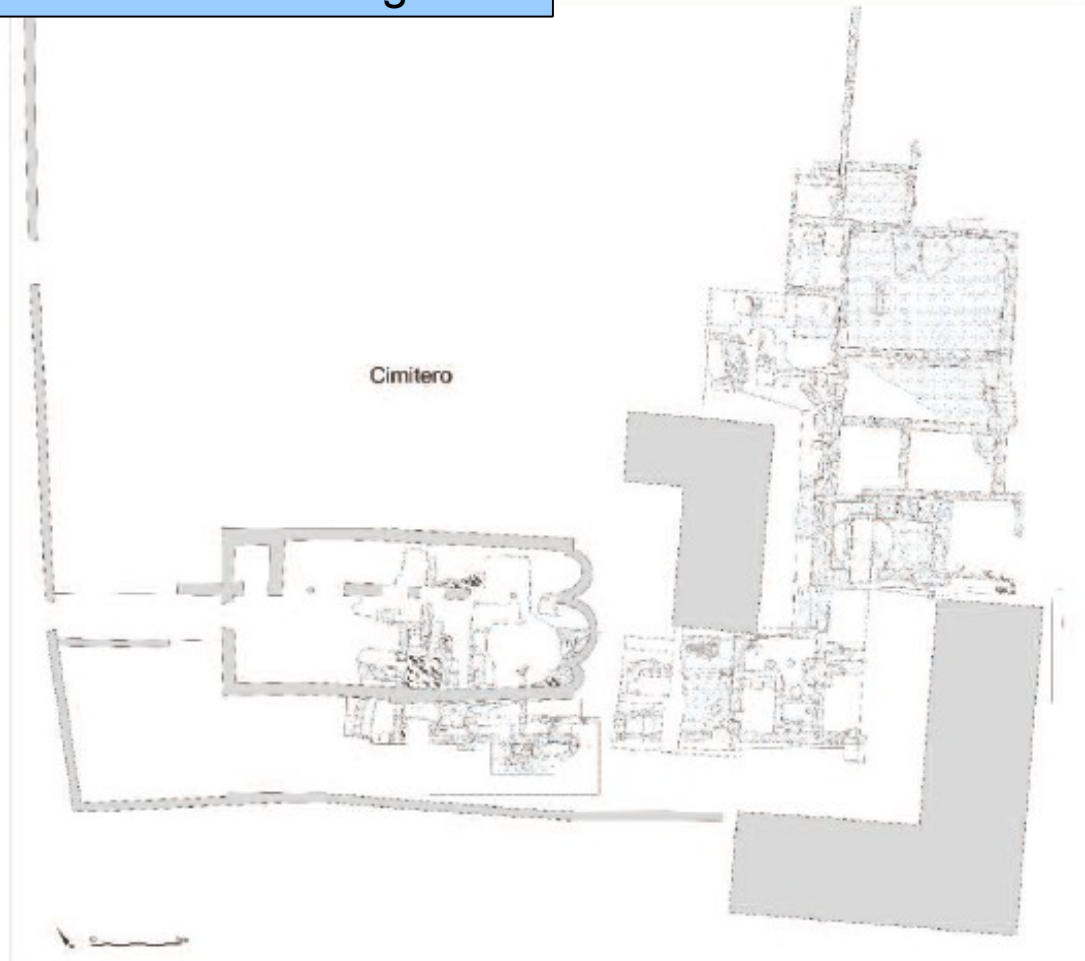

## Castelletto di Brenzone

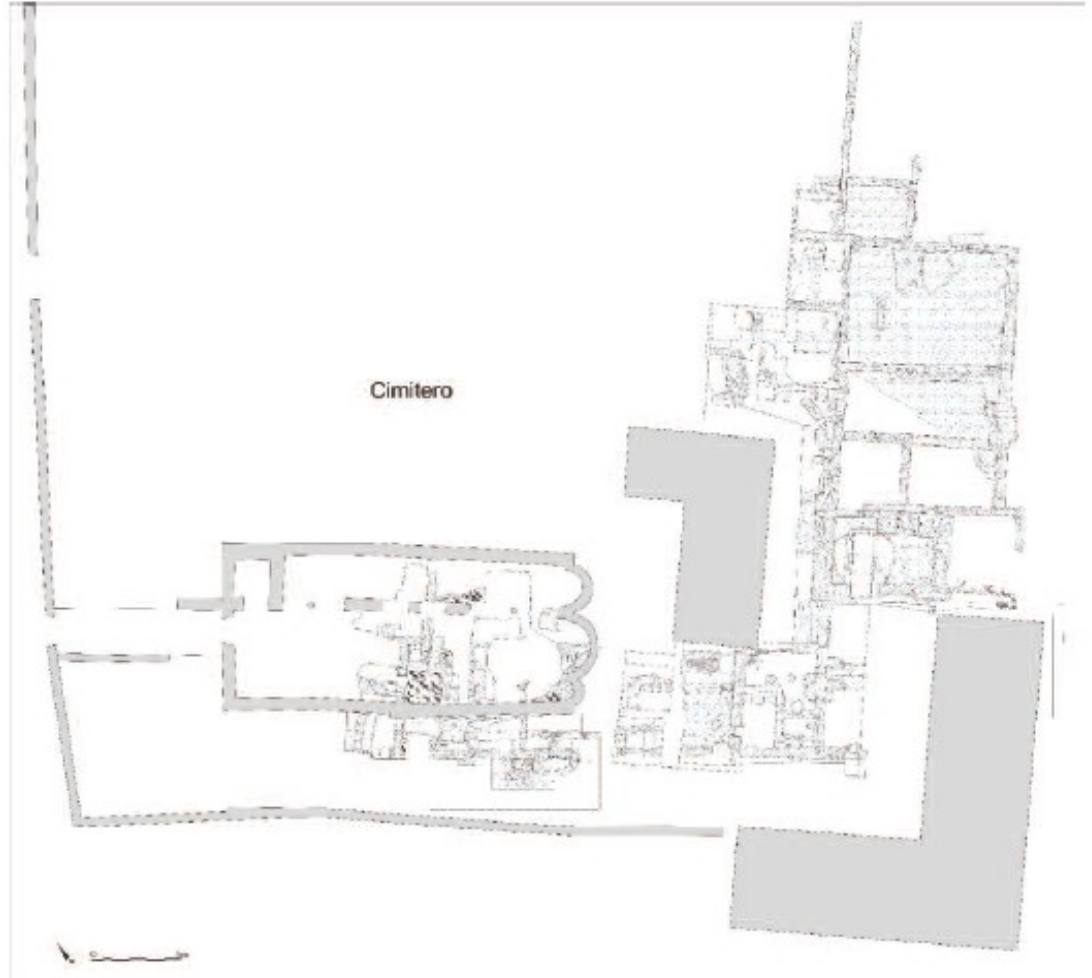

Fig. 5. Veduta del vano con mosaico, ipocausto e prefurnio.

# Castelletto di Brenzone



Fig. 7. Veduta di alcuni vani interessati da attività di spoglio.

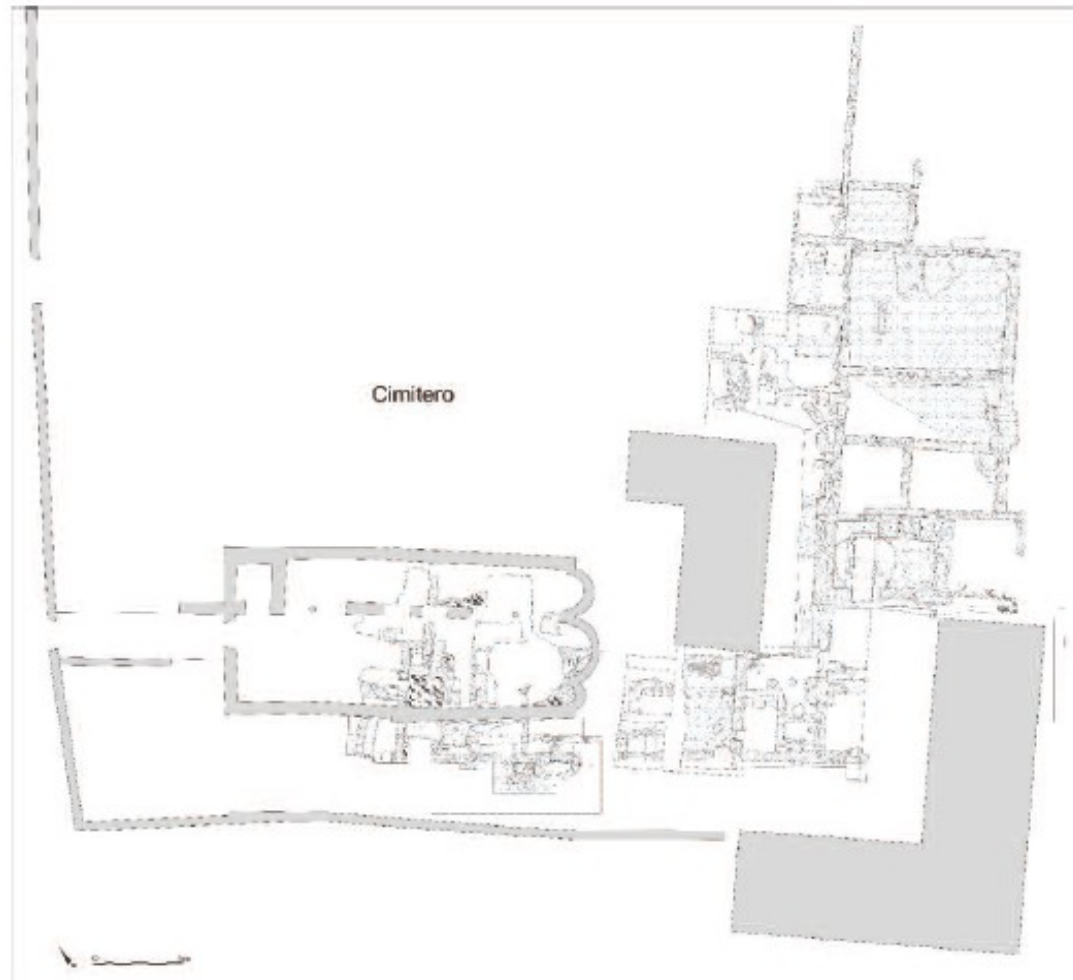
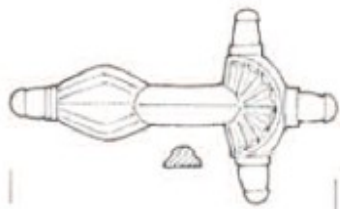



Fig. 13. Focolare d'angolo con suspensurae di riempigio.

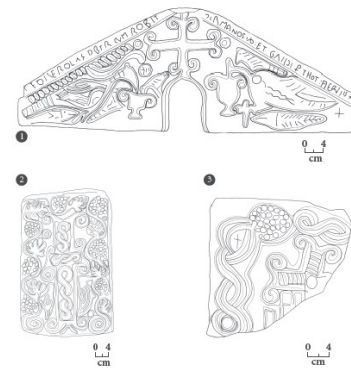
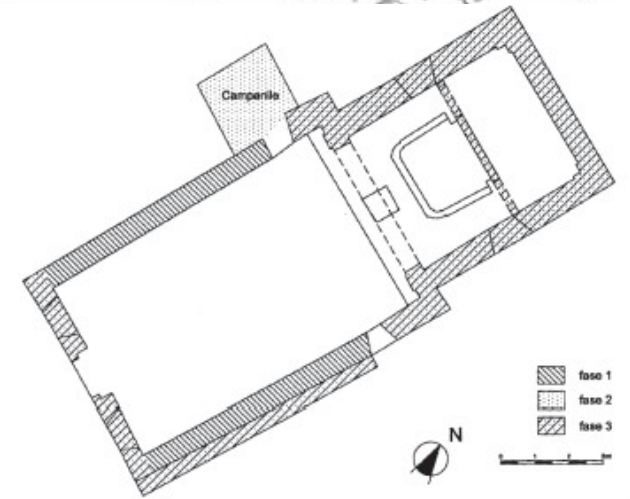
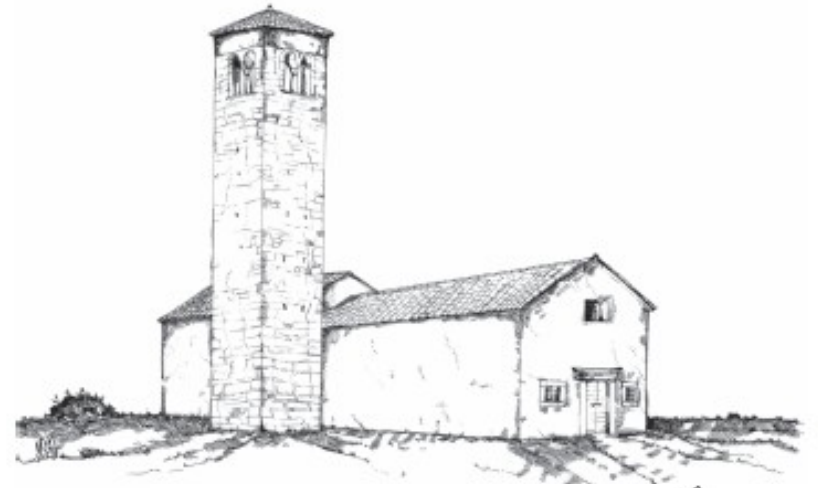

Fig. 14. Olla in ceramica grezza rinvenuta in una cantina interrata (dis. R. Giacometti).



Fig. 15. Chiesa e sepolture della I fase altomedievale (in rosso) con indicazioni delle strutture della villa riutilizzate (in giallo).





# Luogo di culto

# Una società che cambia

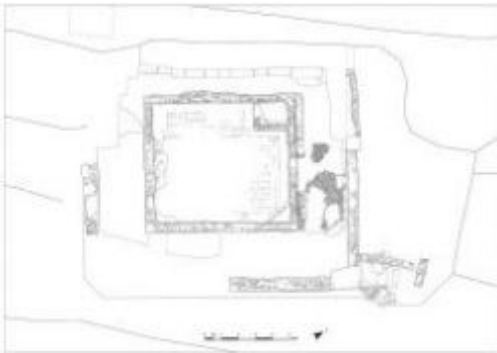

# San Martino ai Campi (TN)



La distruzione dei templi pagani

# Ipogeo di S. Maria in Stelle

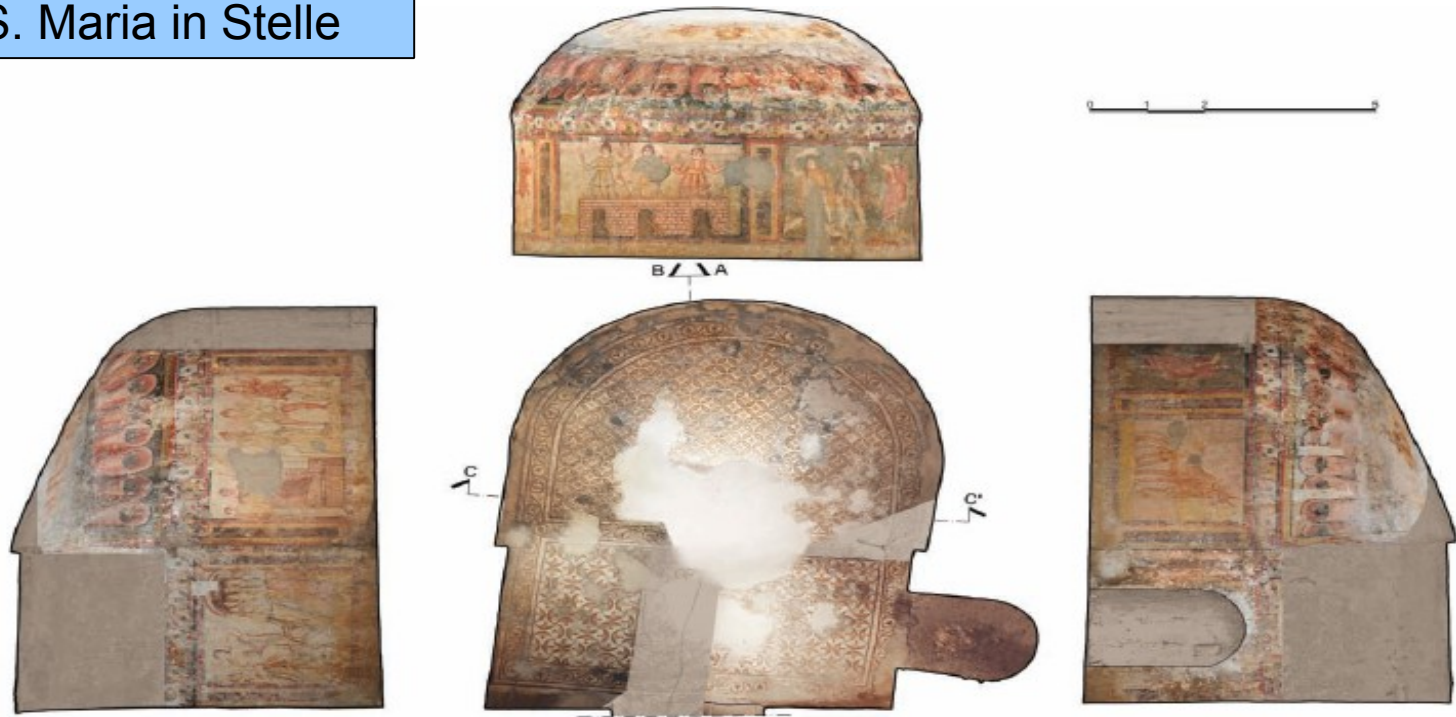
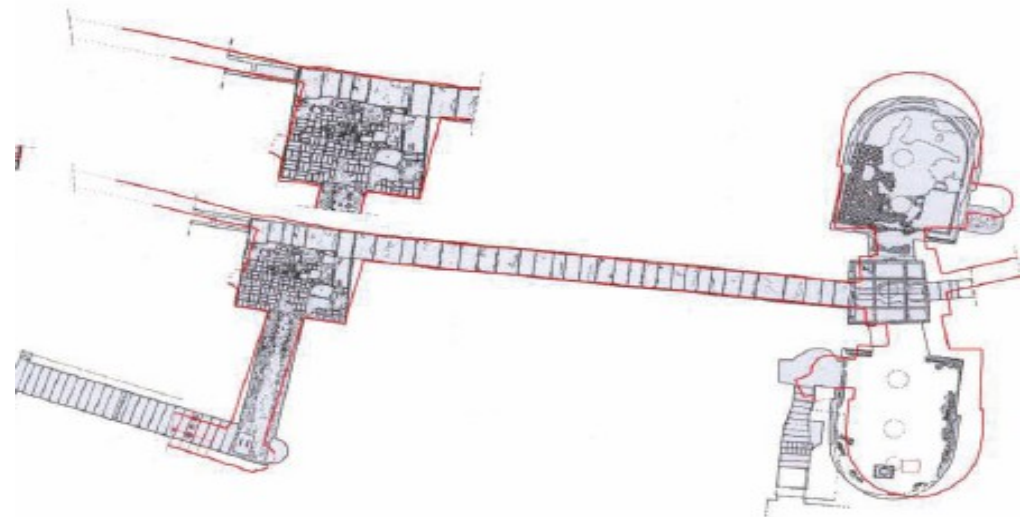

Figure 3: Plan view and elevations rendered with floor's photoplan and wall's orthophoto.





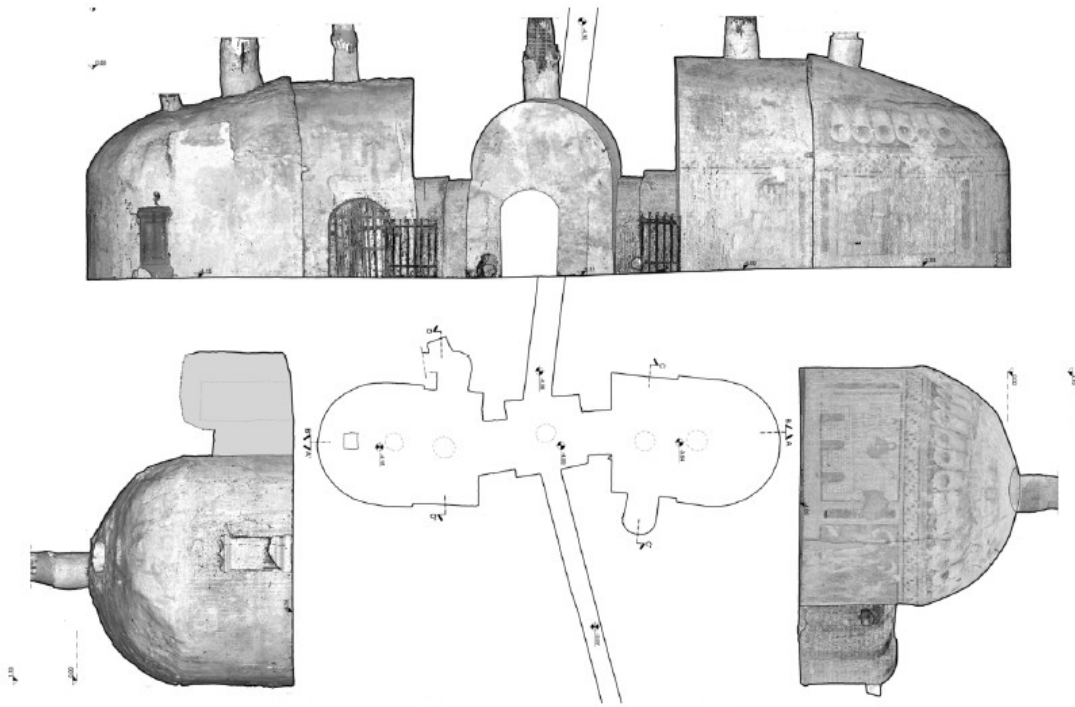
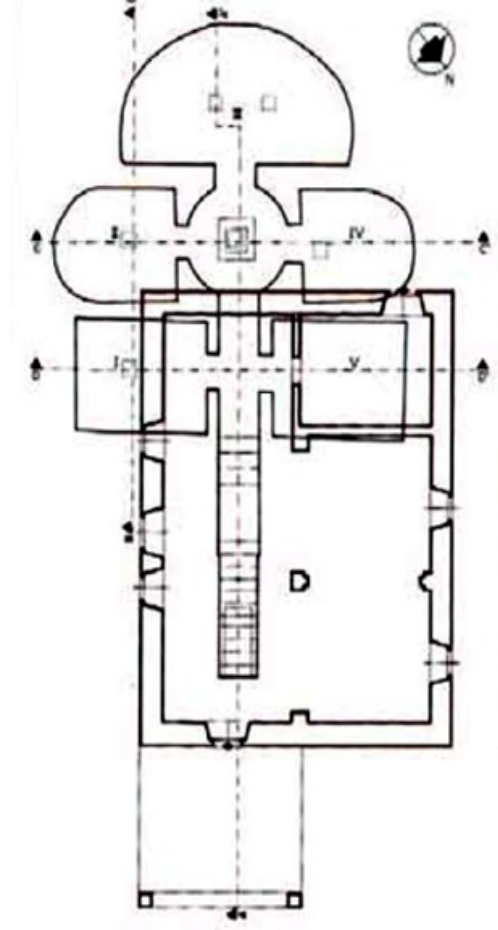

Figure 2: Plan view and elevations rendered with point cloud image in gray scale.

© The Eurographics Association 2010.



# Ipogeo di S. Maria in Stelle

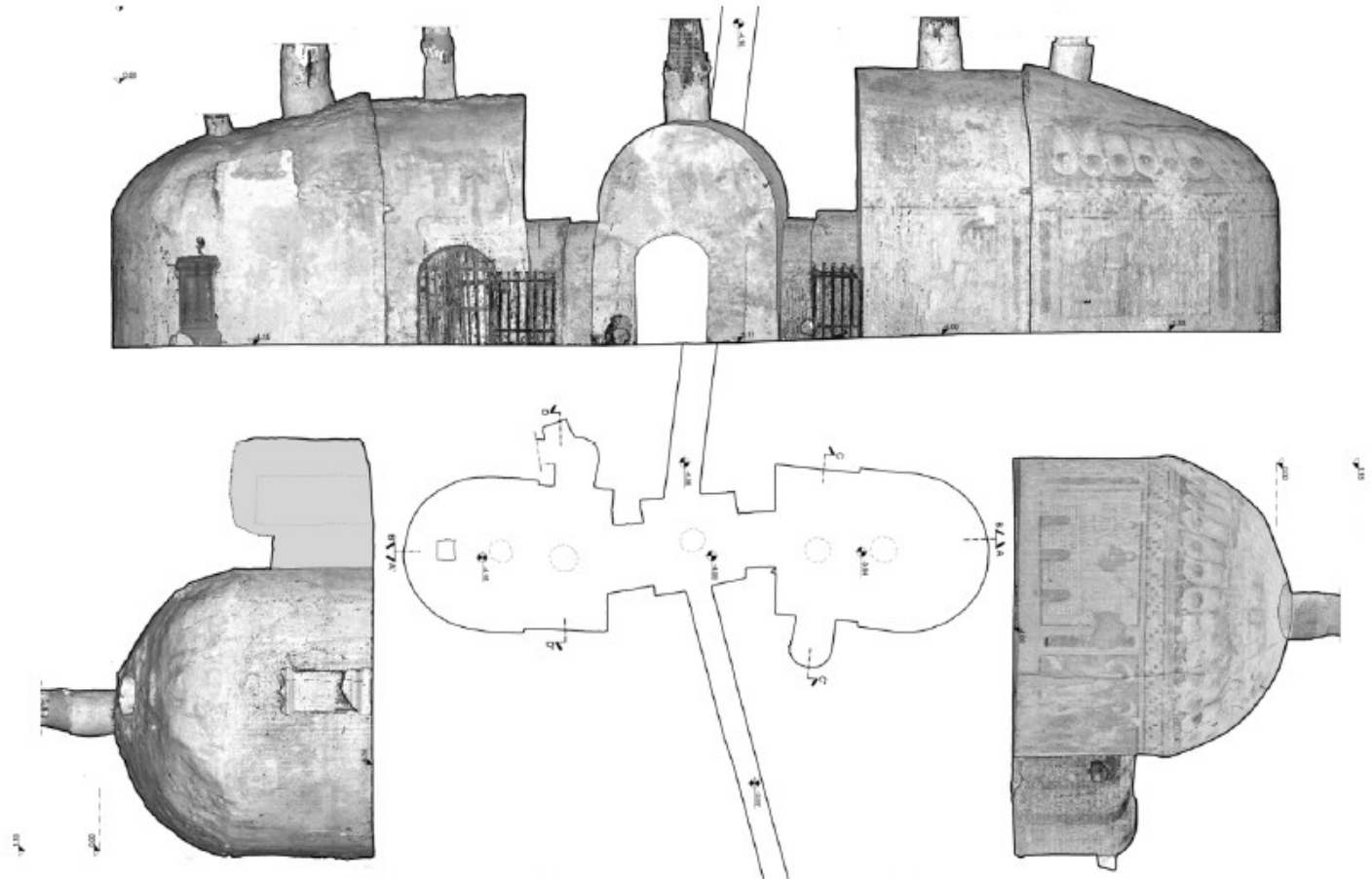
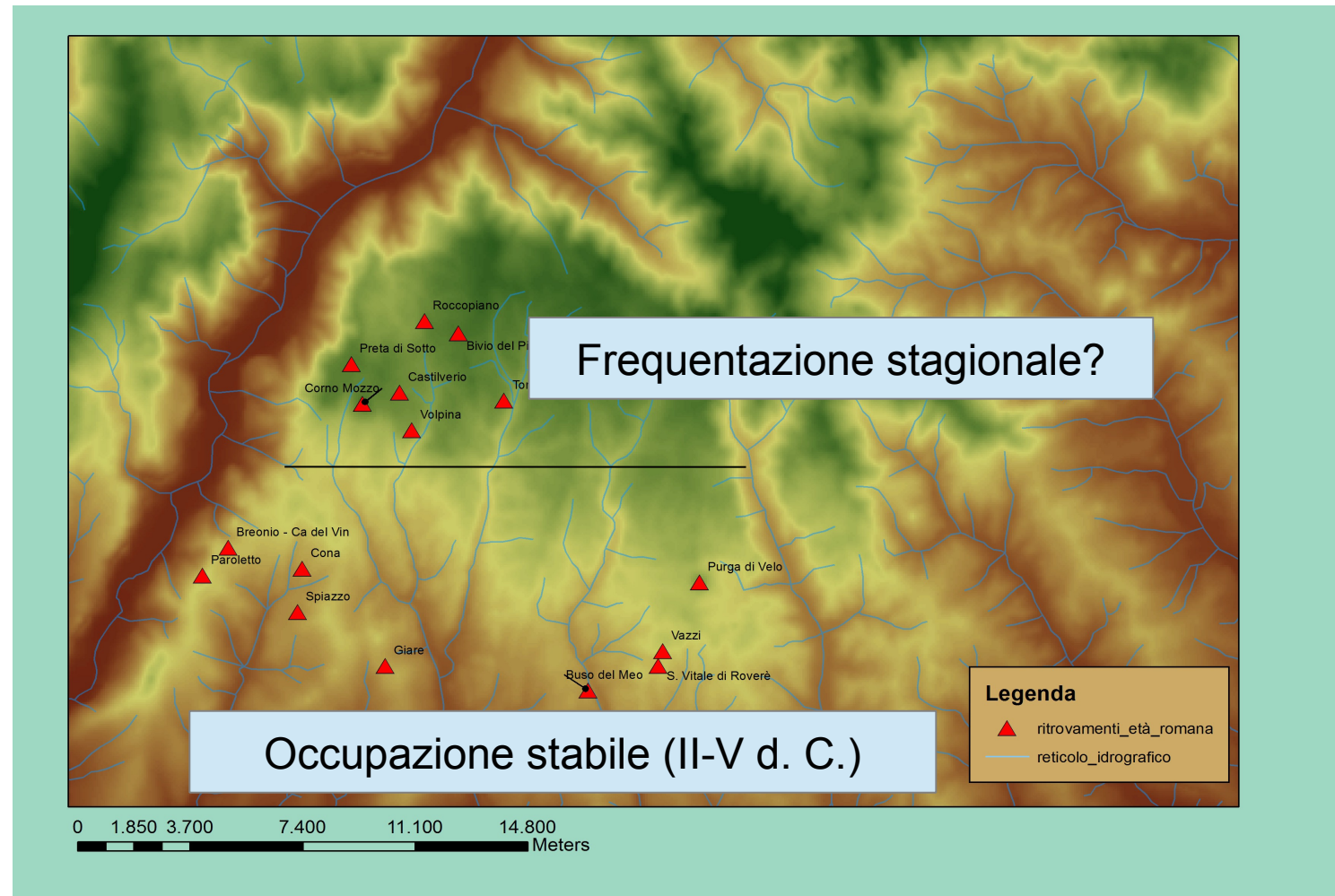

Figure 2: Plan view and elevations rendered with point cloud image in gray scale.

# Luoghi





Luoghi

Bassa Pianura

Alta Pianura

Zona collinare

Montagna

Ambiente

Economia

Società

Villae

Altri insediamenti

Luoghi di culto

Memoria

Tipologia di siti

